



Upright Microscope
ECLIPSE
Ci/Ni

Feel the evolution

Nikon developed the clinical and laboratory microscope ECLIPSE Ci series to meet the demands of a microscope that provides comfortable posture during observation and simple set-up, such as magnification switching, light intensity reproduction and image capturing. With its small footprint, the Ci series delivers compact and space-saving observation conditions. Nikon also developed the ECLIPSE Ni series, which offers high optical quality and a wide range of imaging possibilities. The highly-evolved Ci/Ni series microscopes enable routine analysis with more comfort and greater flexibility than ever before.

Ci

● Eco Friendly

High-intensity, long-life and power saving illumination

● Ergonomic

Flexible, adjustable design to suit the user's natural posture

● Easy to Use

One-touch operation for microscope* control and image capturing

● Versatile

Flexible observation with a wide range of specimens

*Ci-E

Ni

● High-quality

Superior optical performance

● Expandability

Wide variety of optional motorized accessories

● Automation*

Intelligent, automatic switching of observation methods

*Ni-E

● Meeting user needs in clinical microscopy

I want to easily capture images.

I want to conduct observation in comfort.

I want to observe images with bright and even illumination.

I want to simplify operation with motorized accessories.

I want to use a variety of observation techniques.

I want to reduce the number of lamp replacements.

The Ci meets all your demands.

The ECLIPSE Ci series microscopes offer a bright field of view, high durability, comfortable posture for prolonged observation, simple motorized operation, and various illumination techniques that you need for clinical and laboratory microscopy.

Eco Friendly

- **Eco-illumination (Ci-E/Ci-L)**

The newly developed high luminescent LED is a low power consumption eco-friendly light source that produces evenly distributed illumination and reduces the cost and effort of lamp replacement thanks to its long-life.

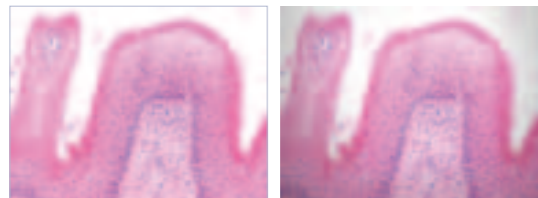

Viewed with Eco-illumination

Viewed without Eco-illumination

*These images are captured without using the shading compensation to emphasize the vignetting.

- **Ceramic-coated stage**

The stage is coated with high durability scratch-resistant coating.



Ergonomic

- **Ergonomic binocular tube**

Eyepiece angle and extension are adjustable. A camera can be mounted via the DSC port.



Ergonomic binocular tube

- **Eyelevel riser**

Eye-point height can be adjusted to suit your natural posture and increases flexibility for multi-users of different heights.

- **Lower stage positioning**

Lower stage height using the nosepiece spacer for easy specimen exchange.



Nosepiece spacer

- **Stage handle with height adjustment**

Smooth stage movement is possible in a comfortable hand position.

Easy to use

- **Image capture button**

One simple click of the button during observation enables you to capture your specimen image with the Digital Sight camera.



- **Motorized magnification change (Ci-E)**

Magnification can be switched with one button control during observation, which automatically memorizes and reproduces user-defined light intensity.



- **Camera control unit DS-L3**

The DS-L3's touch panel allows you to easily set and control your cameras as well as take simple measurements. It is also possible to switch the Ci-E's objective lenses.



Versatile

- **Flexible observation methods**

The high-intensity Eco-illumination and accessories enable you to perform phase contrast, darkfield and simple polarizing microscopy.

- **Image sharing**

The live image can be displayed on the DS-L3 monitor or via a projector. Simultaneous observation on networked PCs is also possible.



● **Auto light intensity reproduction**

The user-defined light intensity for each objective lens is automatically memorized and replicated when the objective is used again. This eliminates the need for manual re-adjustment of light intensity.

● **Nosepiece rotating buttons**

The nosepiece can be rotated allowing you to keep your eyes on the specimen. Your two favorite magnifications can be registered*, and one press of the button alternates between these two objective lenses. This is useful when frequent change of magnifications is necessary, for example between 10x and 40x objectives.

* Magnifications can be registered using the remote control pad's toggle mode.



● **Eco-illumination**

Provides streamlined observation with motorized operation

Motorized model with LED illumination

Equipped with motorized magnification switching and automatic intensity reproduction, it is ideally suited to applications and sample analysis that require frequent magnification switching.

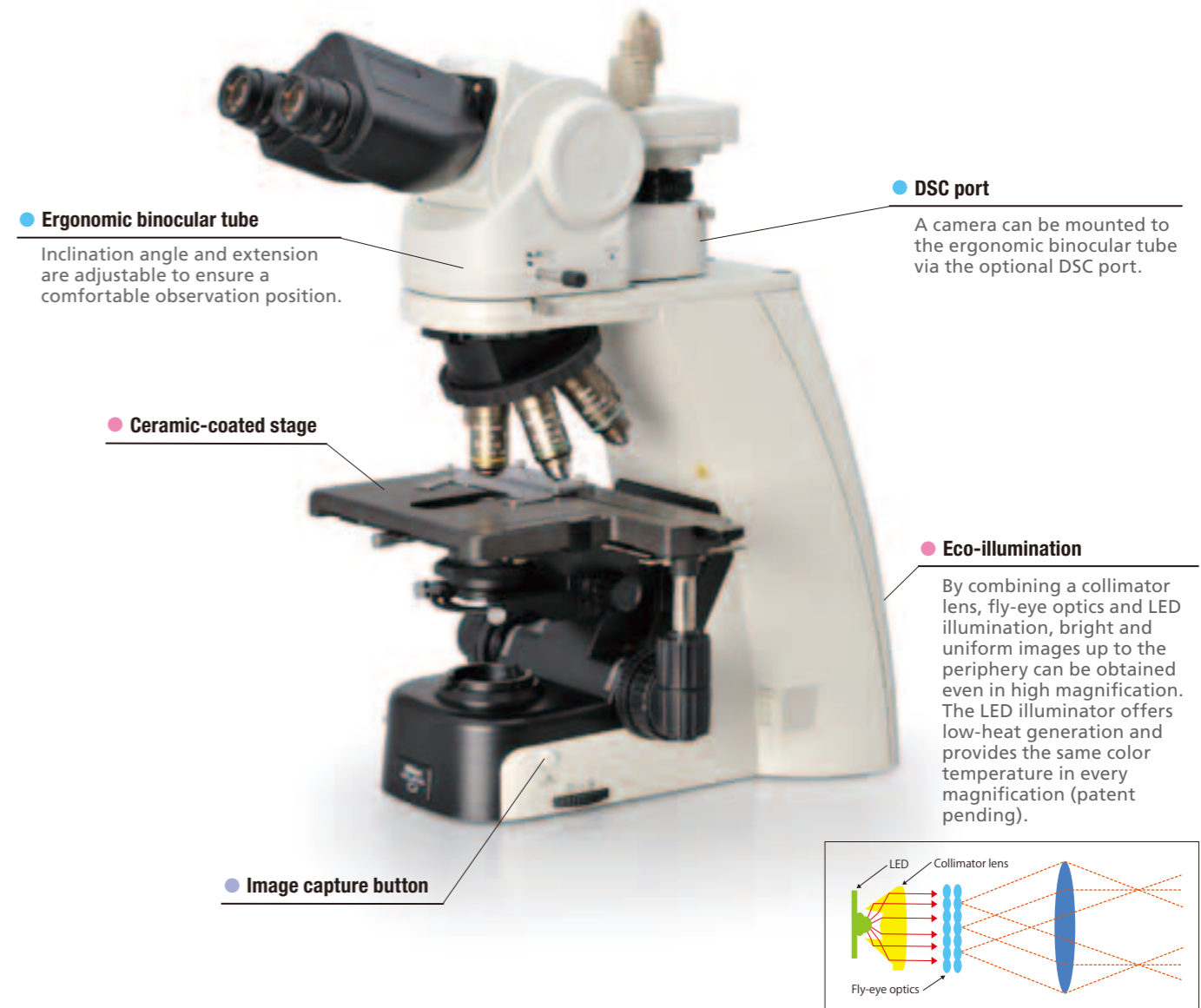

● **Ergonomic binocular tube**

Inclination angle and extension are adjustable to ensure a comfortable observation position.

● **DSC port**

A camera can be mounted to the ergonomic binocular tube via the optional DSC port.

● **Ceramic-coated stage**

● **Eco-illumination**

By combining a collimator lens, fly-eye optics and LED illumination, bright and uniform images up to the periphery can be obtained even in high magnification. The LED illuminator offers low-heat generation and provides the same color temperature in every magnification (patent pending).

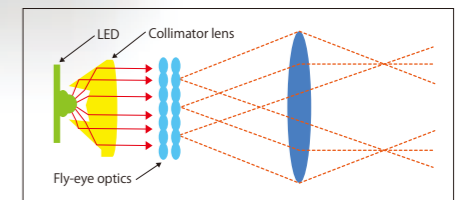

High-intensity and uniform Eco-Illumination

Manual model with LED illumination

Featuring Eco-illumination bright enough for phase contrast and simple polarizing microscopy while reducing lamp replacement with a long-life of 60,000 hours.



● Ergonomic binocular tube

● Ceramic-coated stage

The stage is coated with an abrasion and chemical-resistant ceramic coating, allowing long-term frequent specimen changes without damaging the stage surface.

● Image capture button

● Space-saving compact design

The compact body with an extremely small footprint gives the user more desk space than ever.

● Halogen illumination

● ND4/ND8 filter, NCB11 filter

Changing light intensity is possible by inserting and removing an ND (Neutral Density) filter. The NCB filter for color temperature compensation of the light source is built-in.

Enhanced basic performance for observation

Manual model with halogen illumination

With a small footprint and superior operability the ECLIPSE Ci series offers a comfortable, ergonomic viewing position.

Versatile observation techniques

Using accessories, the Ci-E, Ci-L and Ci-S enable various observation techniques to meet the demands of a wide range of uses, from clinical examination to research.

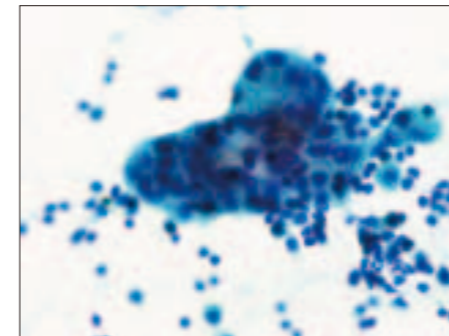

Breast Cancer, Pleural effusion, Papanicolaou stain, CFI Plan Apo λ 60x

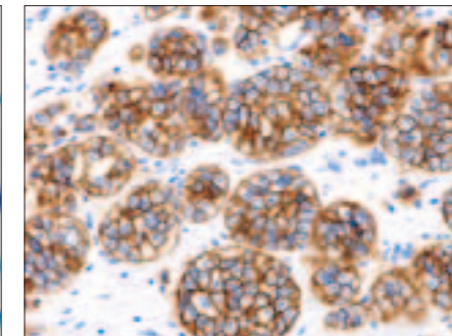

Breast Cancer, HER2/neu, Immunostaining, CFI Plan Apo λ 40x

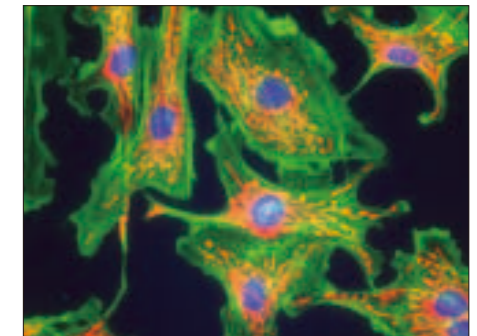

Epi-fluorescence

①② Yoji Urata, Department of Pathology, Kyoto City Hospital

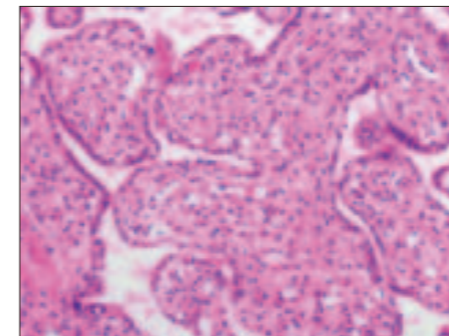

Human Placenta, HE stain, CFI Plan Apo λ 10x

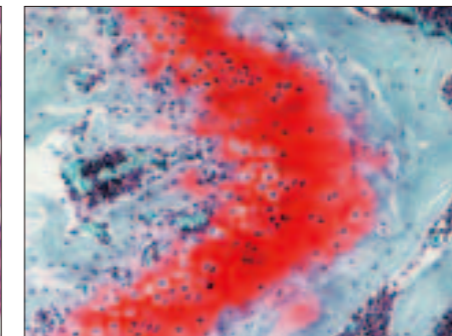

Cartilage of mouse femur, Safranin O fast green iron hematoxylin stain, CFI Plan Apo λ 10x

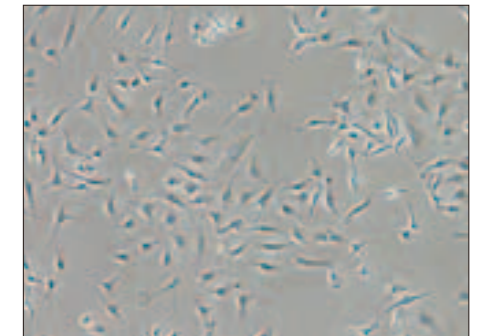

Phase contrast

③④ Atsushi Furuhashi, Noriyoshi Sueyoshi, Division of Biomedical Imaging Research, Juntendo University Graduate School of Medicine

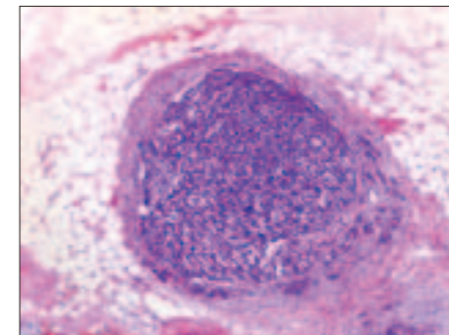

Pancreas Neuro-endocrine Tumor, HE stain, CFI Plan Apo λ 4x

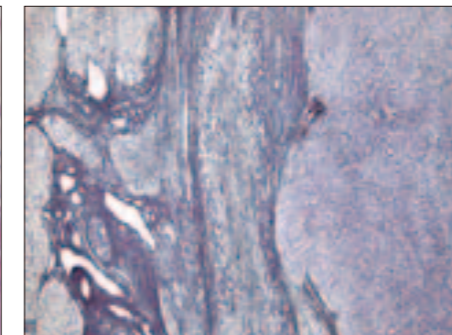

HCC, Silver stain, CFI Plan Apo λ 4x

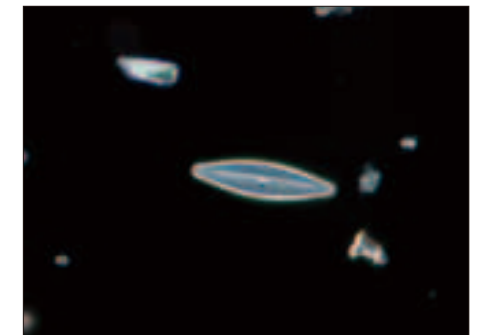

Darkfield

⑤⑥ Kazuhiro Muraoka, Imaging Information Research Center Photography Division, Tokyo Women's Medical University

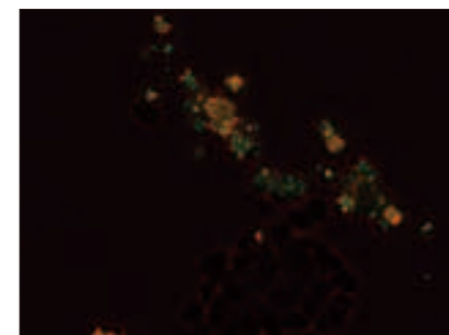

2,8-Dihydroxyadenine crystals, Simple polarizing, CFI Plan Fluor 40x



Sodium urate crystals, Sensitive color polarizing, CFI Plan Fluor 40x

⑦⑧ Department of Clinical laboratory, Nihon University Itabashi Hospital

Digital imaging evolved

In response to user demand for the easy capture of sample images, the ECLIPSE Ci series has a built-in dedicated capture button on the microscope base. An optional digital imaging system supports simple camera settings and operation including capturing, measuring and image sharing.

Image capture button

Image capturing with the digital camera Digital Sight series is possible with the one-touch button located on the microscope base, thereby improving workload efficiency.



Digital Sight series camera control unit DS-L3

The DS-L3 is a stand-alone controller with a large-size touch panel, which allows simple setting and operation of a Digital Sight camera without a computer. The camera control is possible with mouse operation or touch panel operation by finger touch or stylus pen. Configurations of the PC-use control unit DS-U3 and the imaging software NIS-Elements are also available.



Scene mode icons

Optimal camera setting for each observation technique is possible by simply choosing an icon of the observation technique.

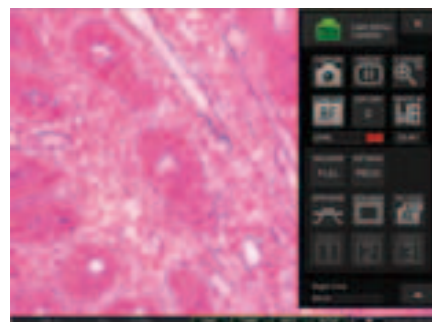

Camera setting

Simple camera setting is possible using icons. The numbers and layout of displayed icons can be customized.



Camera/microscope control

Objective lens switching and condenser setting of the Ci-E are possible.

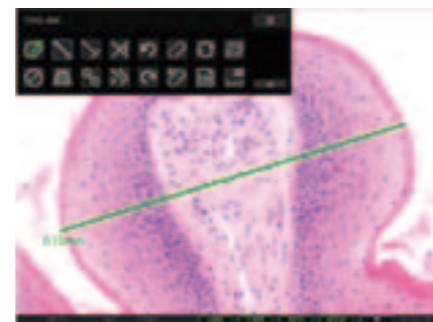

Simple measurement

Simple measurement such as distance measurement between two points is possible.

Observation image sharing

During observation using the ECLIPSE Ci series microscope, live and captured images can be easily shared via the Nikon Digital Sight DS-L3 monitor, projector, or computer monitor. In addition, connecting the ECLIPSE Ci series to a remote PC on the network via a DS-L3 easily enables remote viewing, online education, and distance collaboration.

Digital pathology via a network

When mounting a Digital Sight series digital camera and the camera control unit DS-L3 to the ECLIPSE Ci, image sharing, consultation, and distance learning between multiple PCs is easy. This combination allows live streaming of images on the network through firmware so the capability of the network is not compromised by software. The split-screen capability for real-time comparison of low to high magnification images is an added convenience for remote consultation. In essence, this unique network addressable system is the most powerful tool for consulting in or between hospitals, presentations and conferences during academic meetings, in-class lectures and distance education.



Split-screen display

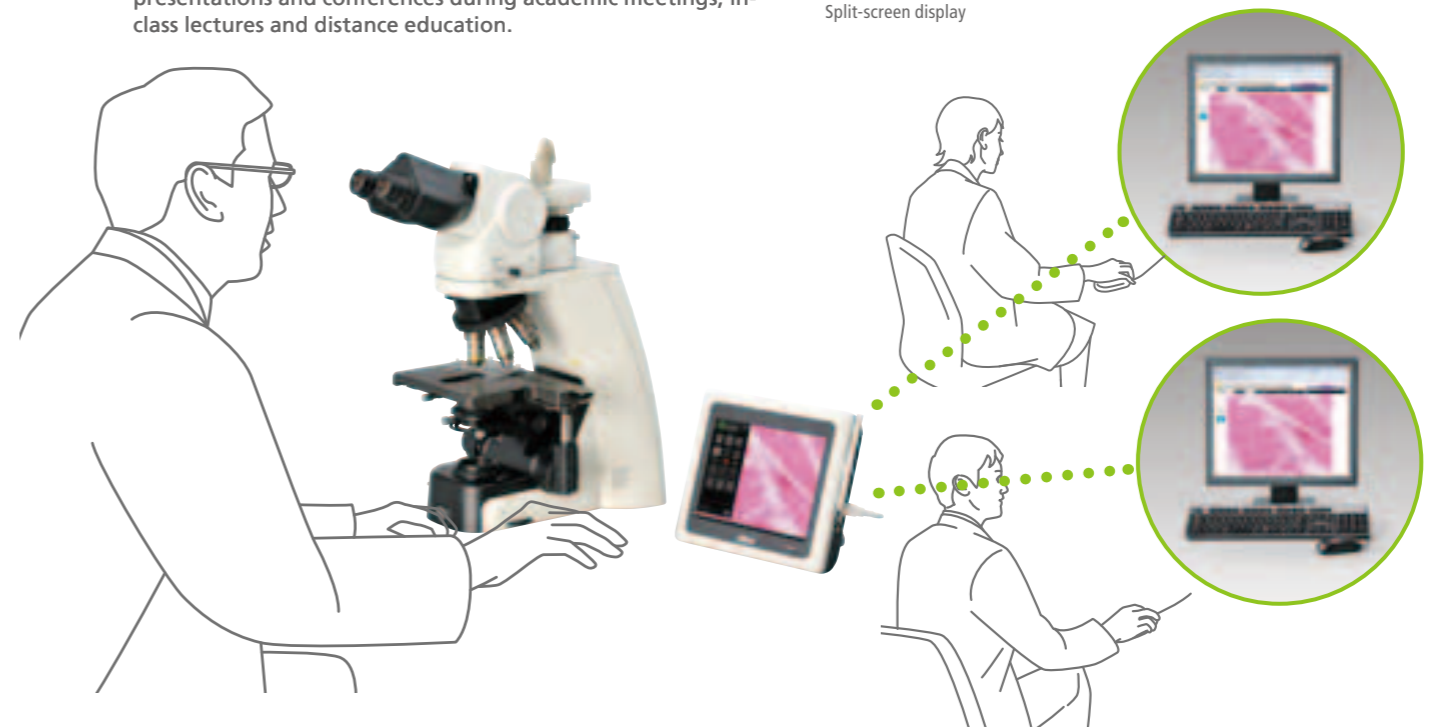

Digital Sight series digital camera heads

Users can select the most suitable camera for their samples and observation techniques from a diverse lineup of compact, high-performance digital camera heads of the Digital Sight series imaging system. (Following is a part of the line-up.)

High-speed color camera head DS-Vi1



Featuring a high frame rate, a 2.0-megapixel CCD, and displaying SXGA live images (1600 x 1200 pixels max.) at 15fps (30fps max.), this camera is ideal for monitoring microscopy images at high-speed, with high-quality live image display.

High-definition color camera head DS-Fi2

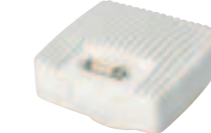

A high-definition 5-megapixel CCD faithfully captures microstructures with resolution as high as 2560 x 1920 pixels. Other advanced features include an enhanced frame rate of up to 21fps and accurate color reproduction. It can be universally used for brightfield, darkfield, or phase contrast image acquisition.

High-definition cooled color camera head DS-Fi1c



A Peltier device cooling mechanism incorporated into the 5-megapixel CCD delivers high-resolution images of up to 2560 x 1920 pixels. This mechanism keeps the CCD at 20°C below its uncooled state to produce high-contrast images with less heat-induced noise. It is ideal for imaging of weak-light structures under fluorescence and darkfield microscopy.

Ci accessories meet additional demands of users

I want to observe using fluorescent microscopy.

The ECLIPSE Ci series has the option of two dedicated compact epi-fluorescence attachments, CI-FL Epi-fluorescence Attachment (4 filter cubes mountable) and D-FL Epi-fluorescence Attachment (6 filter cubes mountable).

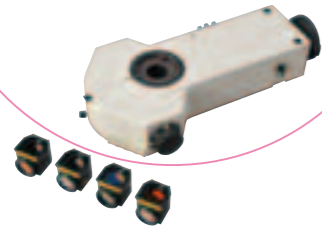

I want to use phase contrast microscopy with LED illumination.

Eco-illumination has sufficient light intensity for phase contrast microscopy that is used in a wide range of applications including dermatological examinations.

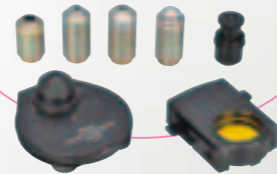

Phase contrast accessories

I want to observe the same view field simultaneously with another person

The teaching head enables multiple peoples to observe the same specimen simultaneously. A bright and long-life LED is employed in the pointer.

* 3-person type and 5-person type are also available.



Side-by-side type

Face-to-face type

I want to more user-friendly stage operation.

The stage height can be lowered 20mm from the standard position by adding a nosepiece spacer, facilitating frequent specimen change.

The stage handle height can be changed to ensure a comfortable hand position.

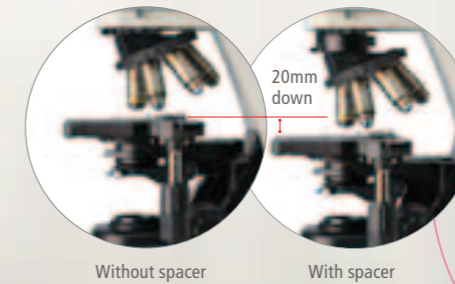

Without spacer

With spacer



I want to perform gout tests.

Eco-illumination is compatible with sensitive color polarizing microscopy, and gout tests can be conducted by observing uric acid crystals.

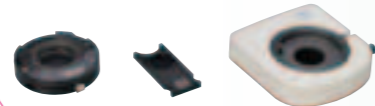

Sensitive color polarizing accessories

I want to reduce the number of times I switch the condenser.

An optional achromat swing-out condenser is compatible with a wide range of magnifications, between 1x to 100x.



I want to be able to quickly and safely change the specimen.

The stage height can be locked using the re-focusing knob, and this facilitates safe refocusing after changing the specimen.

I want to observe specimens with a wider field of view.

Attaching CFI UW 10x/10M eyepiece lenses with F.N. 25mm in combination with a trinocular tube T and trinocular tube F enables wide field microscopy.

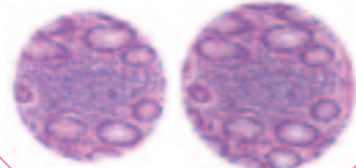

22mm

25mm

I want to easily capture digital images of my specimens.

You can mount a camera on a trinocular tube T, trinocular tube F or an ergonomic binocular tube. Imaging in a comfortable position is possible with an ergonomic binocular tube by mounting the camera via the DSC port. Imaging is possible by simply pushing the image capture button.



Trinocular tube T

Trinocular tube F

Ergonomic binocular tube

I want to undertake long-term observation with minimal discomfort.

The ergonomic binocular tube can be inclined from 10° to 30° and extended up to 40mm. The eyelevel riser lifts the tube in 25mm increments (up to 100mm*).
* Up to 50mm with ergonomic binocular tube.

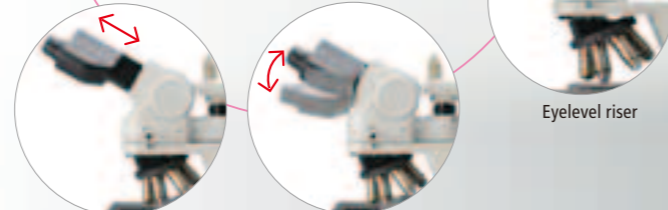

Eyelevel riser

I want to use various objective lenses.

Nikon provides a broad range of objective lenses, such as the CFI Plan Achromat series, which is affordably priced and has high image flatness, the CFI Plan Fluor series, which is suitable for fluorescence microscopy, and the CFI Plan Apochromat λ series, with its superior resolution, brightness and chromatic aberration correction.



Left: Plan Achromat series; middle: Plan Fluor series; right: Plan Apochromat λ series

Two flagship upright microscopes

The newly developed upright microscope ECLIPSE Ni series has high expandability, motorization, and superior optical performance.

Ni-E is a fully motorized model provides the most suitable observation settings without manual adjustment. The aperture and field diaphragm or condenser is automatically adjusted when the magnification is changed.

Ni-U is suitable for many observations, from clinical examination to research, and featuring motorized accessories that include nosepiece, fluorescence attachment, and shutter.



Motorized model with automatic observation switching



● **Fly-eye optics**

The fly-eye optics built into the transmitted-light illumination system provides bright and uniform illumination across the entire field of view.



● **Superior optical performance**

Nikon offers high quality optical technologies such as exclusive low-reflective Nano Crystal Coat to produce objective lenses. The CFI Plan Apo Chromat λ series objective lenses offer remarkably high transmission and superior chromatic aberration correction throughout a broad range of wavelengths and are suitable for near-IR observation.



● **Noise terminator**

The noise terminator mechanism is equipped with fluorescent filter cubes and turrets that eliminate stray light, and enables you to capture high contrast fluorescence images with a high S/N ratio.

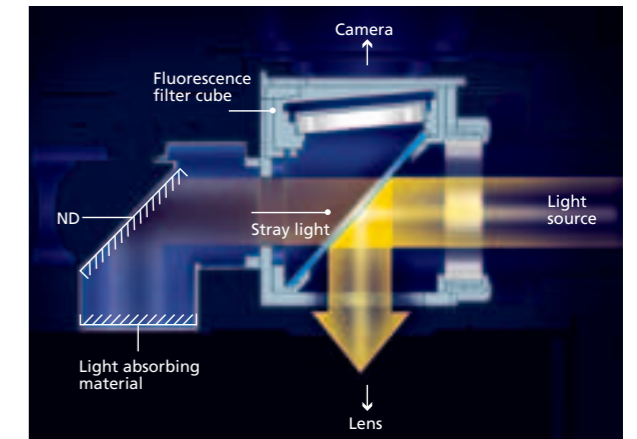

Manual model with motorization capability

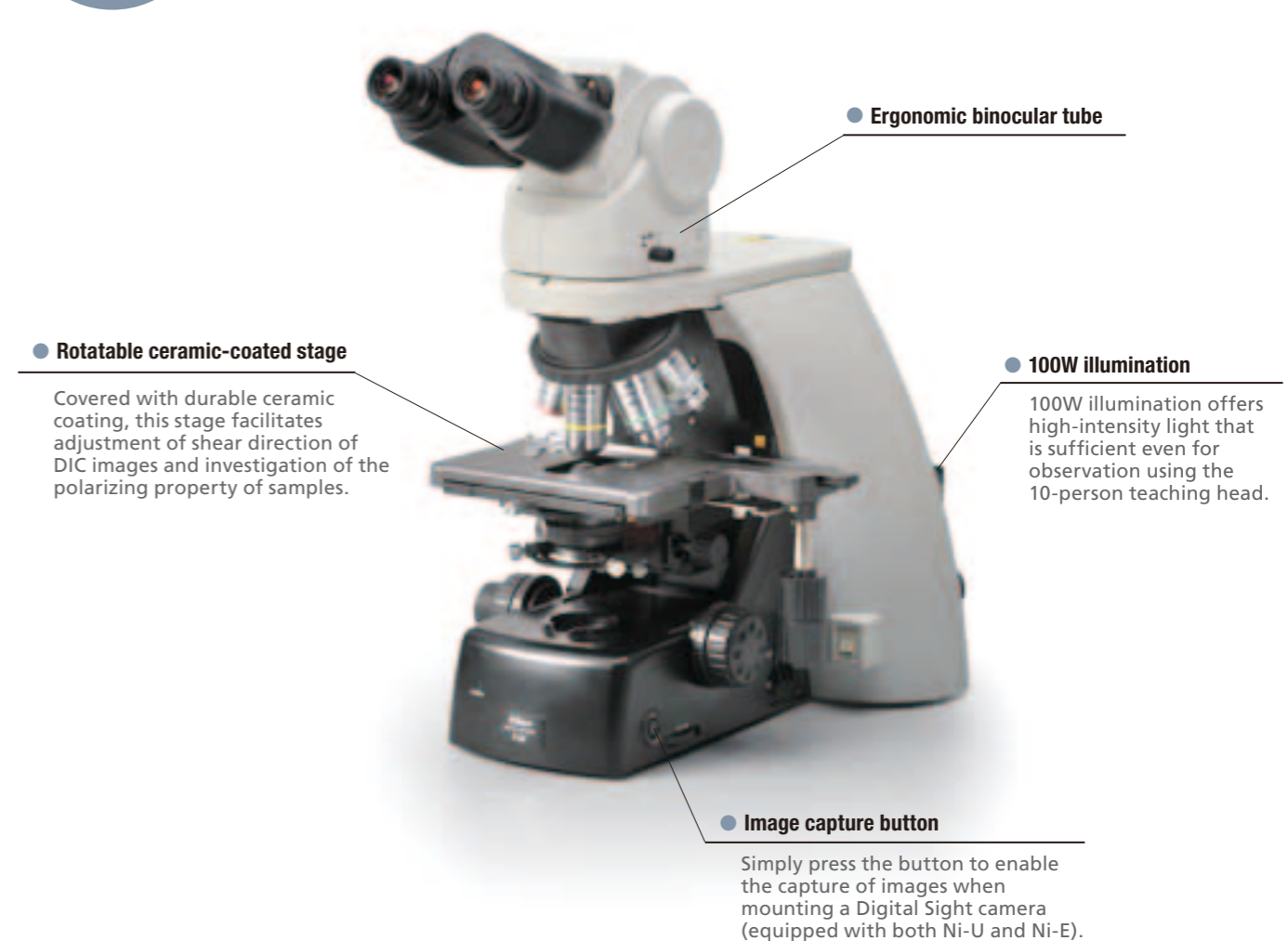

Ci System Diagram

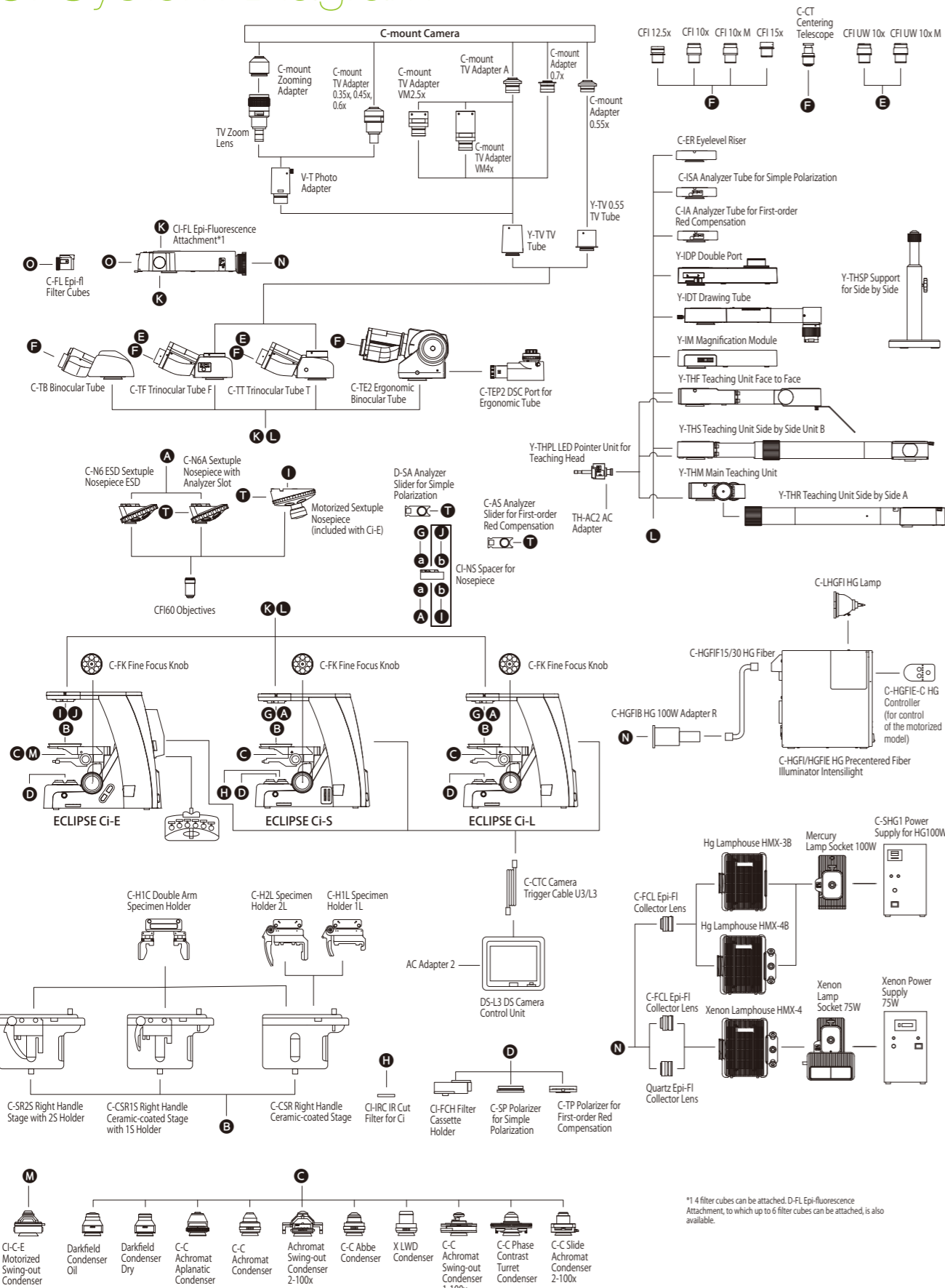

*1 4 filter cubes can be attached. D-FL Epi-fluorescence Attachment, to which up to 6 filter cubes can be attached, is also available.

Specifications

		Ci-E	Ci-L	Ci-S
Main body	Optical system	CFI60 Infinity Optical System		
	Illumination	High luminescent White LED Illuminator (Eco-illumination)		6V30W Halogen Lamp Built-in ND4, ND8, NCB11 filters
		Automatic intensity reproduction function		—
	Controls	Image capture button		—
		Nosepiece rotating buttons Remote control pad		—
Eyepieces (F.O.V. mm)	· CFI 10× (22) · CFI 10×M photomask (22) · CFI 12.5× (16) · CFI 15× (14.5) · CFI UW 10× (25) · CFI UW 10×M photomask (25)			
Focusing	Coaxial Coarse/Fine focusing, Focusing stroke: 30 mm, Coarse: 9.33 mm/rotation, Fine: 0.1 mm/rotation Coarse motion torque adjustable, Refocusing function			
Tubes	F.O.V. 22 mm (Eyepiece/Port)	· C-TB Binocular Tube · C-TE2 Ergonomic Binocular Tube (100/0, 50/50 via optional C-TEP2 DSC Port) Inclination angle: 10-30 degree, Extension: up to 40 mm		
	F.O.V. 25 mm (Eyepiece/Port)	· C-TF Trinocular Tube F (100/0, 0/100) · C-TT Trinocular Tube T (100/0, 20/80, 0/100)		
Nosepieces	· Motorized Sextuple Nosepiece with Analyzer Slot (Within main body) Switching between two objectives function		· C-N6 ESD Sextuple Nosepiece ESD · C-N6A Sextuple Nosepiece with Analyzer Slot	
Stages	Cross travel 78 (X) × 54 (Y) mm, with vernier calibrations, stage handle height and torque adjustable for all stages C-H1C Double Arm Specimen Holder is available as an option for the below three stages. · C-SR2S Right Handle Stage with 2S Holder · C-CSR1S Right Handle Ceramic-coated Stage with 1S Holder · C-CSR Right Handle Ceramic-coated Stage (C-H2L Specimen Holder 2L and C-H1L Specimen Holder 1L can be attached)			
Condensers (NA)	Motorized	· C-C-E Motorized Swing-out Condenser (0.9/0.22) Focusing stroke: 27 mm		—
	Manual	Focusing stroke: 27 mm · C-C Abbe Condenser (0.9) · C-C Achromat Condenser (0.8) · Darkfield Condenser Oil (1.2-1.43) · Darkfield Condenser Dry (0.8-0.95) · C-C Phase Contrast Turret Condenser (0.9) · C-C Achromat Aplanatic Condenser (1.4) · C-C Slide Achromat Condenser 2-100× (0.9) · C-C Achromat Swing-out Condenser 1-100× (0.8/0.12) · Achromat Swing-out Condenser 2-100× (0.9/0.22) · X LWD Condenser (0.65)		
Observation methods*	Brightfield, Epi-fluorescence, Darkfield, Phase contrast, Simple polarizing, Sensitive color polarizing			
Epi-fluorescence attachment	· C-FL Epi-fluorescence Attachment (4 filter cubes mountable) · D-FL Epi-fluorescence Attachment (6 filter cubes mountable) ND4/ND8/ND16 filters, Noise Terminator mechanism			
Epi-fluorescence light source	· C-HGFI/HGFI HG Precentered Fiber Illuminator Intensilight (130W) · Hg Lamphouse and Power Supply (100W) · Xenon Lamphouse and Power Supply (75W)			
Power consumption	13W (Brightfield configuration)	6W (Brightfield configuration)	38W (Brightfield configuration)	
Weight (approx.)	15.4 kg (Binocular standard set)	13.4 kg (Binocular standard set)	13.4 kg (Binocular standard set)	

*Observations except Brightfield require optional accessories.

Dimensional Diagram

Unit: mm

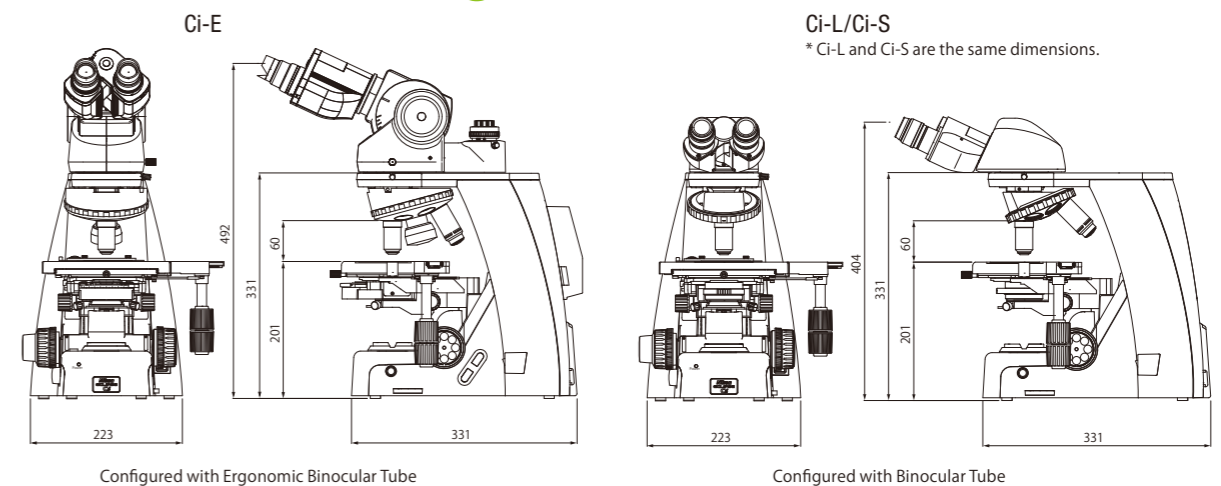

Configured with Ergonomic Binocular Tube

Configured with Binocular Tube

Ni-E/U System Diagram

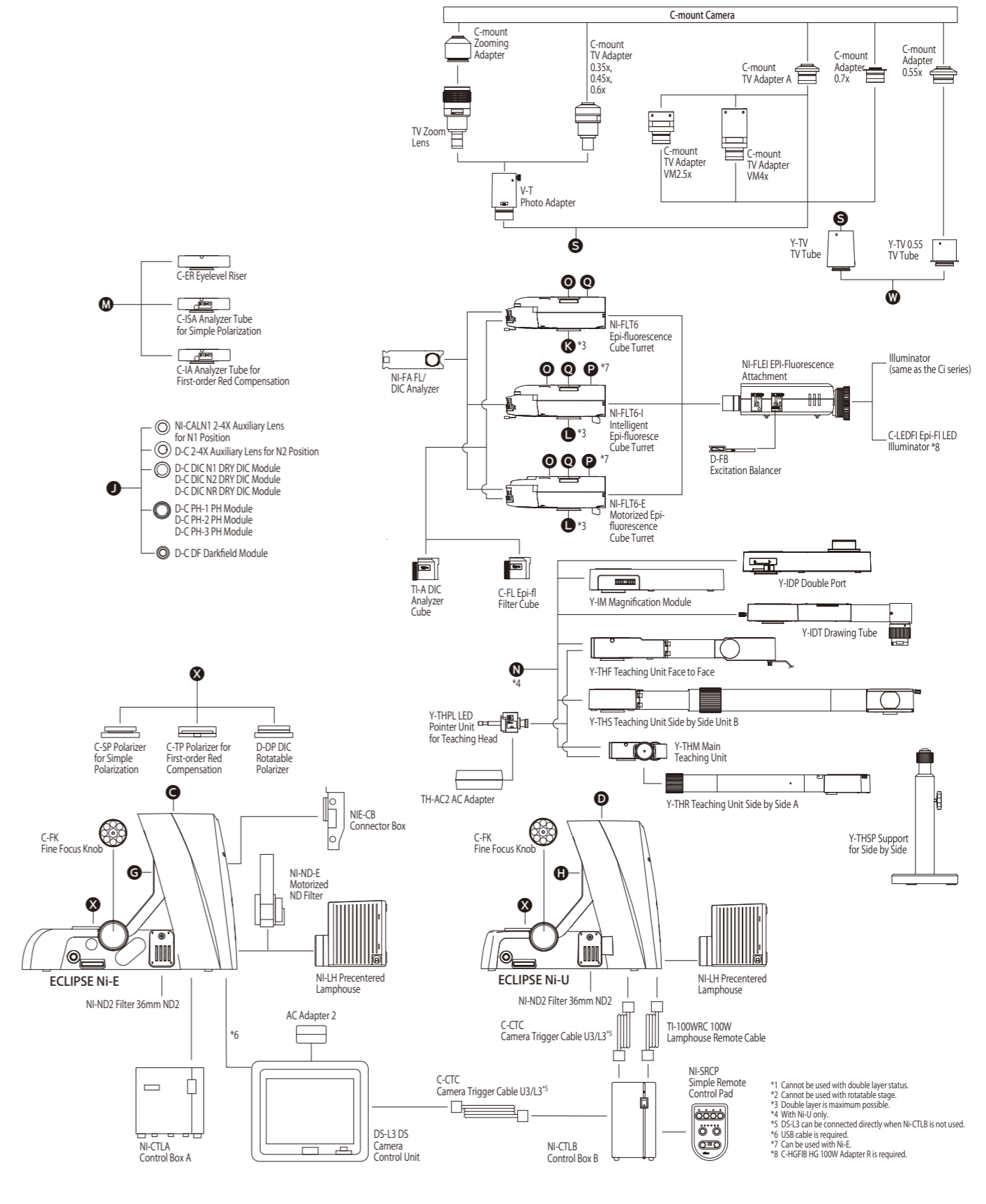
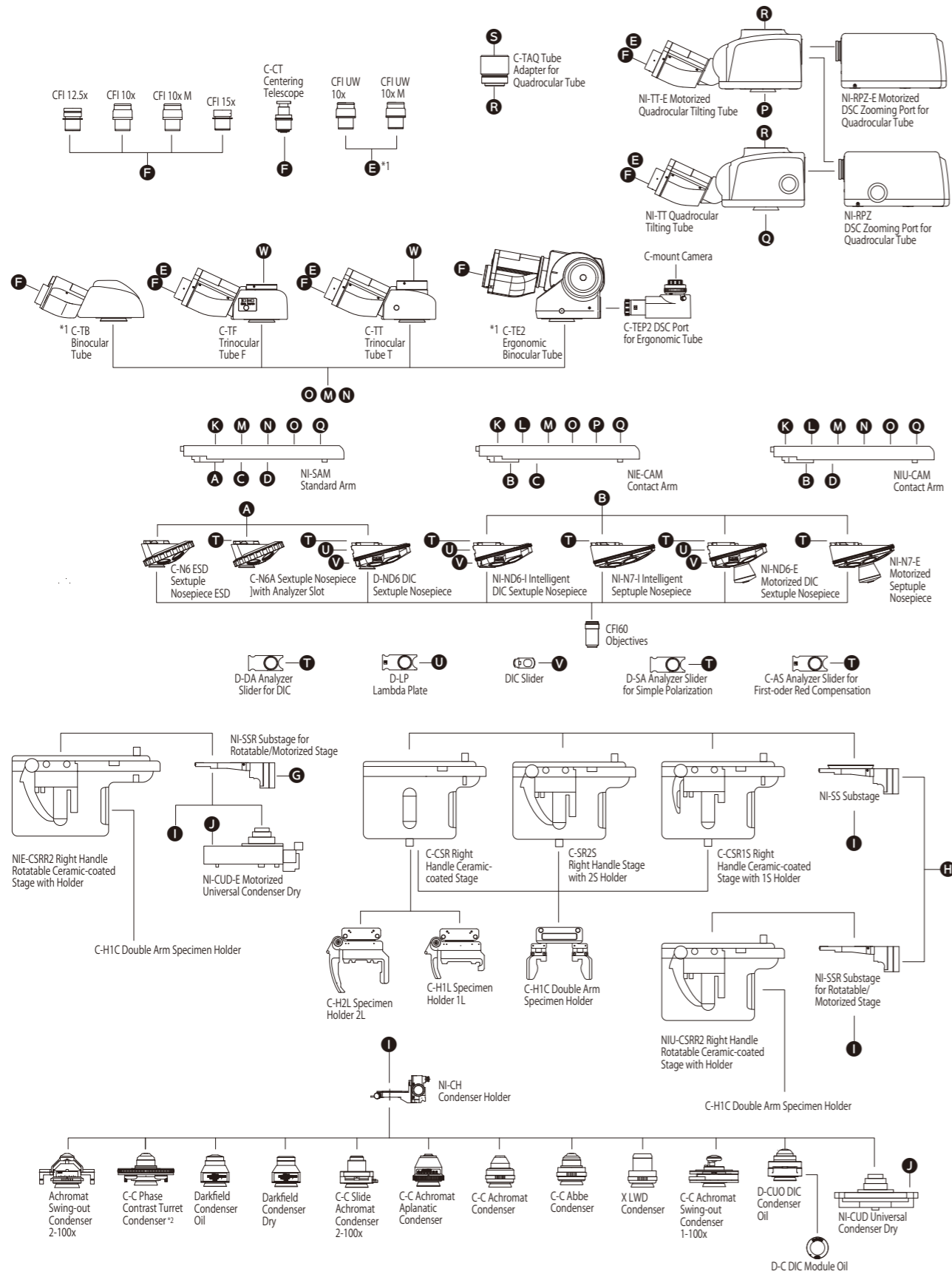

*1 Cannot be used with double layer status.
 *2 Cannot be used with rotatable stage.
 *3 Double layer is maximum possible.
 *4 With Ni-U only.
 *5 DS-L3 can be connected directly when NI-CTLB is not used.
 *6 USB cable is required.
 *7 Can be used with Ni-E.
 *8 C-HGFB HG 100W Adapter R is required.

Company names and product names appearing in this brochure are their registered trademarks or trademarks.
 N.B. Export of the products* in this brochure is controlled under the Japanese Foreign Exchange and Foreign Trade Law.
 Appropriate export procedure shall be required in case of export from Japan.
 *Products: Hardware and its technical information (including software)
 Monitor images are simulated.

Specifications and equipment are subject to change without any notice or obligation on the part of the manufacturer. December 2013 ©2011-13 NIKON CORPORATION

	WARNING	TO ENSURE CORRECT USAGE, READ THE CORRESPONDING MANUALS CAREFULLY BEFORE USING YOUR EQUIPMENT.
---	----------------	--



NIKON CORPORATION

Shin-Yurakucho Bldg., 12-1, Yurakucho 1-chome, Chiyoda-ku, Tokyo 100-8331, Japan
 phone: +81-3-3216-2375 fax: +81-3-3216-2385
<http://www.nikon.com/instruments/>



ISO 9001 Certified
 NIKON CORPORATION
 Instruments Company



ISO 14001 Certified
 NIKON CORPORATION

NIKON INSTRUMENTS INC.

1300 Walt Whitman Road, Melville, N.Y. 11747-3064, U.S.A.
 phone: +1-631-547-8500; +1-800-52-NIKON (within the U.S.A. only)
 fax: +1-631-547-0306
<http://www.nikoninstruments.com/>

NIKON INSTRUMENTS EUROPE B.V.

Tripolis 100, Burgenveeshuispad 101, 1076 ER Amsterdam,
 phone: +31-20-7099-000 fax: +31-20-7099-298
<http://www.nikoninstruments.eu/>

NIKON INSTRUMENTS (SHANGHAI) CO., LTD.

CHINA phone: +86-21-6841-2050 fax: +86-21-6841-2060
 (Beijing branch) phone: +86-10-5831-2028 fax: +86-10-5831-2026
 (Guangzhou branch) phone: +86-20-3882-0552 fax: +86-20-3882-0580

NIKON SINGAPORE PTE LTD

SINGAPORE phone: +65-6559-3618 fax: +65-6559-3668

NIKON MALAYSIA SDN. BHD.

MALAYSIA phone: +60-3-7809-3688 fax: +60-3-7809-3633

NIKON INSTRUMENTS KOREA CO., LTD.

KOREA phone: +82-2-2186-8400 fax: +82-2-555-4415

NIKON CANADA INC.

CANADA phone: +1-905-602-9676 fax: +1-905-602-9953

NIKON FRANCE S.A.S.

FRANCE phone: +33-1-4516-45-16 fax: +33-1-4516-45-55

NIKON GMBH

GERMANY phone: +49-211-941-42-20 fax: +49-211-941-43-22

NIKON INSTRUMENTS S.p.A.

ITALY phone: +39-055-300-96-01 fax: +39-055-30-09-93

NIKON AG

SWITZERLAND phone: +41-43-277-28-67 fax: +41-43-277-28-61

NIKON UK LTD.

UNITED KINGDOM phone: +44-208-247-1717 fax: +44-208-541-4584

NIKON GMBH AUSTRIA

AUSTRIA phone: +43-1-972-6111-00 fax: +43-1-972-6111-40

NIKON BELUX

BELGIUM phone: +32-2-705-56-65 fax: +32-2-726-66-45

